



SMART  
**SENSOR**  
BUSINESS

# LSIS 400*i* SERIES

Simple quality assurance  
and identification through  
high-performance  
camera technology

*easy*handling.



# THE INTELLIGENT EYE FOR AUTOMATION

The LSIS 400i series – the smart camera of the next generation.

## YOUR ADVANTAGES IN DETAIL

- **Measurement function** facilitates efficient use in many applications
- **Three functions in one device** (BLOB analysis, code reading, measurement through edge scanning)
- **Inexpensive – everything in one device:** Illumination, image processing, image and program memory, display, display of the results, interfaces
- **Fast integration:** Operation via standard web browser, networking via Ethernet
- **Easy to operate:** Well-structured software with online help, integrated display with control panel
- **High availability:** No configuration software that needs to be installed separately, independent of the operating system, everything is stored in the device
- **Reliable function:** Very homogeneous illumination over the entire field of view through specially developed lenses
- **Flexible illumination for every task:**  
Pulsed or continuous operation, four individually switchable lighting segments
- **Various light colors of the integrated illumination available:** white, infrared or RGBW
- **No manual alignment during batch changes:**  
Automated, motor-driven focus and illumination adjustment
- **No opening of the housing:** Digital adjustment of the illumination and focus position via software, protection against tampering and soiling
- **Low integration costs:** All interfaces (Ethernet, RS 232, 8x digital I / O) are integrated, no interfacing units are necessary
- **Short commissioning times:** Simple mounting with dovetail or threaded holes
- **Industrial – robust:** Safe with EMC, shock, vibrations, IP65 / 67, scratch-resistant protective glass or plastic window, M12 connection technology
- **Everything from a single source:** Mounting brackets, cables, adapters, connectors, additional lighting and much more

**easy**handling.





## FASTER INTEGRATION THROUGH WEBCONFIG

- Configuration directly via the web browser
- Faster and easier access to the device via Ethernet interface
- No configuration software needs to be installed on the PC

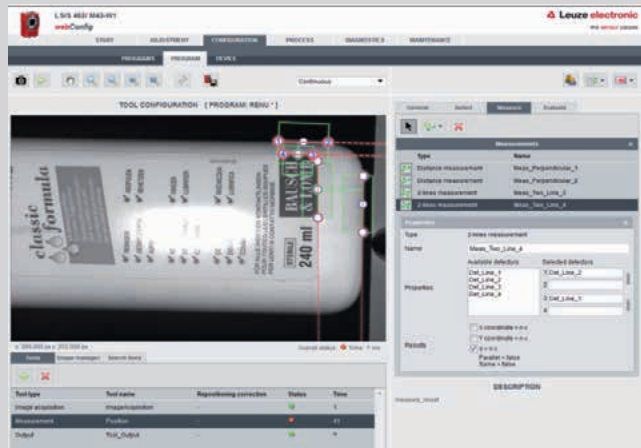

## MORE FLEXIBLE USE THROUGH MOTOR-DRIVEN FOCUS ADJUSTMENT

- During batch change, the check program is loaded with the focus setting for the specific camera distance. The corresponding focus position is moved to via motor-driven focus adjustment, i.e., no manual focusing is necessary on the device
- Motor-driven focus adjustment is also an advantage if there is very limited installation space in the machine or the smart camera was installed in such a way that it is not accessible from the outside during normal operation



## BETTER RESULTS THROUGH HOMOGENEOUS ILLUMINATION

- Rectangular, intense and uniformly illuminated field of view that is particularly homogeneous at a distance of 50 mm to 250 mm to the test object
- Compared to conventional LED illumination, the captured image is illuminated much more homogeneously and with greater detail. This makes it better and faster for image processing and improves the reliability of the processing

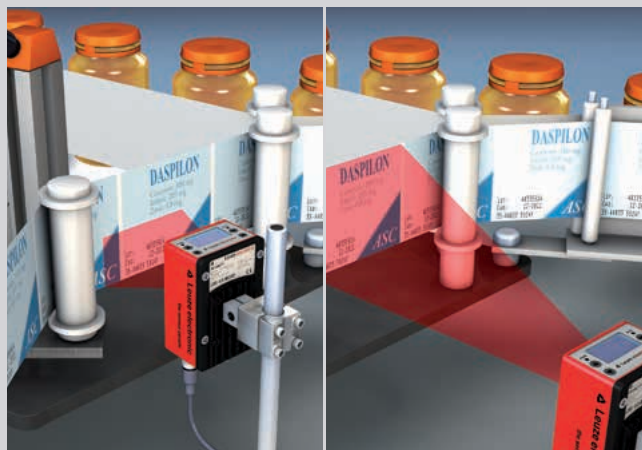



# LSIS 412i – THE CAMERA WITH BLOB

Intelligent, pixel-perfect image processing.

BLOB stands for “binary large object” and identifies a contiguous area of pixels whose light intensity lies between defined limit values. By setting BLOB features, individual objects or object groups can be reliably detected and differentiated on the basis of their geometric

features – also when other processes already supply incorrect results. Typical applications of BLOB analysis are the inspection for presence, completeness or the type, position and orientation detection.

## FUNDAMENTAL EVALUATION CRITERIA OF OBJECTS DURING BLOB ANALYSIS

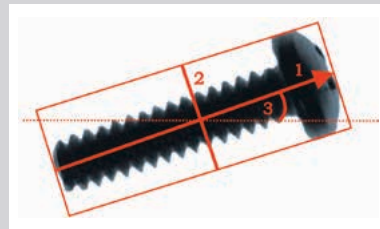
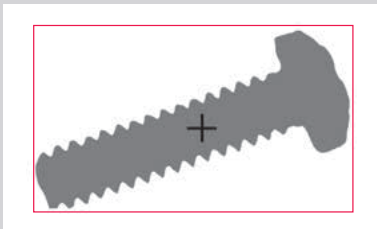

- **Surface:** Sum of the pixels enclosed in a BLOB; optionally including possible holes within the BLOB
- **Circumference:** Length in pixels of the outer contour of a BLOB
- **Shape factor:** Ratio between surface and circumference of the BLOB
- **Height / width:** Height and width of the smallest rectangle that encloses the BLOB with sides parallel to the X- and Y-axes
- **Center X / Y:** X- and Y-coordinates of the area centroid of the BLOB
- **Length of the major axis (1):** Length of the smallest rotated rectangle that encloses the BLOB
- **Length of the minor axis (2):** Height of the smallest rotated rectangle that encloses the BLOB
- **Angle of the major axis (3):** Orientation of the major axis – measured to the “heavy” side of the BLOB, relative to the X-axis (0° ... 360°)

# B ANALYSIS

## PRACTICAL BLOB APPLICATIONS.

With the LSIS 412i, you can access a camera system that is equipped with a powerful software-based BLOB-detection tool. Thus a wide range of tasks of completeness and presence testing or position detection can be performed easily and reliably.



Completeness inspection

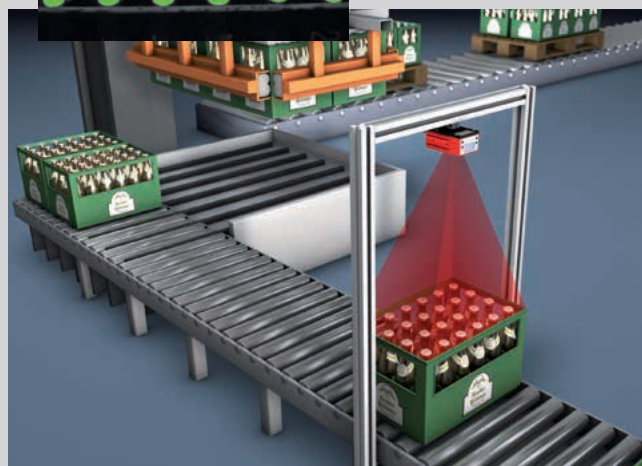

Presence inspection

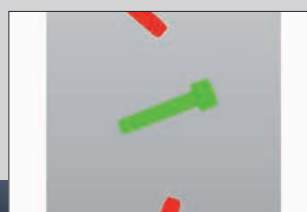

Position and orientation



# LSIS 422i – RELIABLY READ 1D- AND 2D-CODES

The best of two worlds.

The LSIS 422i stationary code reader combines innovative camera technology and decades of know-how from the area of 1D-code reading. It reads 1D- and 2D-codes with absolute reliability, both printed as well as directly marked. And it does so omnidirectionally, statically,

or with fast movement, codes with high or low contrast as well as inverted or reflected codes – even a reference code comparison is possible. The innovations of the LSIS 400i series as well as outstanding illumination and motor-driven focus adjustment help here.

## IMPORTANT FEATURES:

- Reads the most important 1D- and 2D-codes
- Reading of printed, laser-etched or dot-peened codes
- Multiple code reading – up to 99 codes per image
- Default setting enables the reading of 90% of all codes – optimization for code types or for increasing the reading performance is possible
- Display of the code content, configurable data output
- Evaluation of the code quality of printed codes through quality parameters for 1D- and 2D-codes
- Reference code comparison
- Commissioning and operation with a standard web browser – no software installation necessary

# D 2D-CODES

## CODE READING UNDER INDUSTRIAL CONDITIONS.

The LSIS 422i offers maximum reading reliability for many applications:

- Automotive and automotive suppliers
- Circuit board manufacturing
- Semiconductor, photovoltaic and solar
- Packaging (food, beverage and pharmaceutical)
- Conveyor/storage systems
- General: traceability



Code verification



Laser-etched  
Data Matrix code



Dot-peened  
Data Matrix code

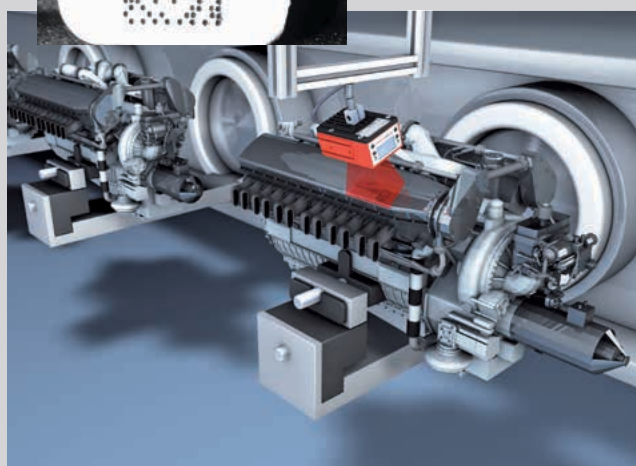

# LSIS 462i – QUALITY INSPECTION AND IN ONE DEVICE

Particularly economical for many applications.

In addition to Blob analysis and code reading, the LSIS 462i smart camera offers the option of measuring distances and geometric shapes such as circles, lines and edges, both with high detection reliability and under a single user interface. With the edge scanning process, all detectable edges can be tested for completeness (edge counting).

The LSIS 462i smart camera can also be used anywhere different labels have to be detected and evaluated at high speed. It reads printed and directly marked 1D/2D-codes, independent of contrast, with absolute reliability. The new version of our top product is the best and – thanks to its attractive price – the most efficient solution for many applications.

## IMPORTANT FEATURES:

- The measurement function in the LSIS 462i makes possible minimal tolerances and thereby reduces, e.g., the scrapping of good parts!
- Three functions in one device (BLOB analysis, code reading, measurement through edge scanning)
- Reliable detection of objects or object groups on the basis of geometric features
- Test for presence, completeness, type, position and orientation
- Position correction in X, Y and rotation (0 ... 360°)
- Omnidirectional reading of the most important 1D- and 2D-codes with reference code comparison
- Reading of printed and directly marked codes, up to 99 codes on each image
- Evaluation of the code quality of printed codes
- Save up to 100 check programs on the device
- Commissioning and operation with a standard web browser – no software installation necessary



# ND CODE READING

## DOUBLE BENEFITS FOR MANY APPLICATIONS.

The LSIS 462i is suitable for many tasks in quality inspection and code reading, e.g.:

- Automotive and automotive suppliers
- Circuit board manufacturing
- Packaging (food, beverage and pharmaceutical)
- Semiconductor, photovoltaic and solar



Presence inspection  
Caps and code reading

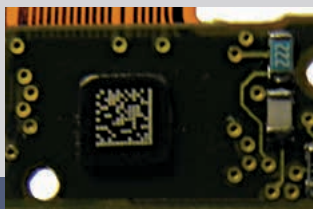

Component completeness  
and traceability



Measurement of the  
label position



# LSIS 400i – TECHNICAL DATA OF THE

Reliably solve complex tasks.

## 8 MM / 16 MM COMPACT LENS

The diagram shows the field of view as a function of the camera distance for focal lengths of 8 mm and 16 mm. The camera distance is the distance between the front edge of the camera and the object.



white light



RGBW

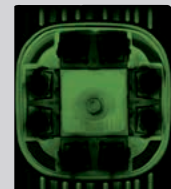

Infrared

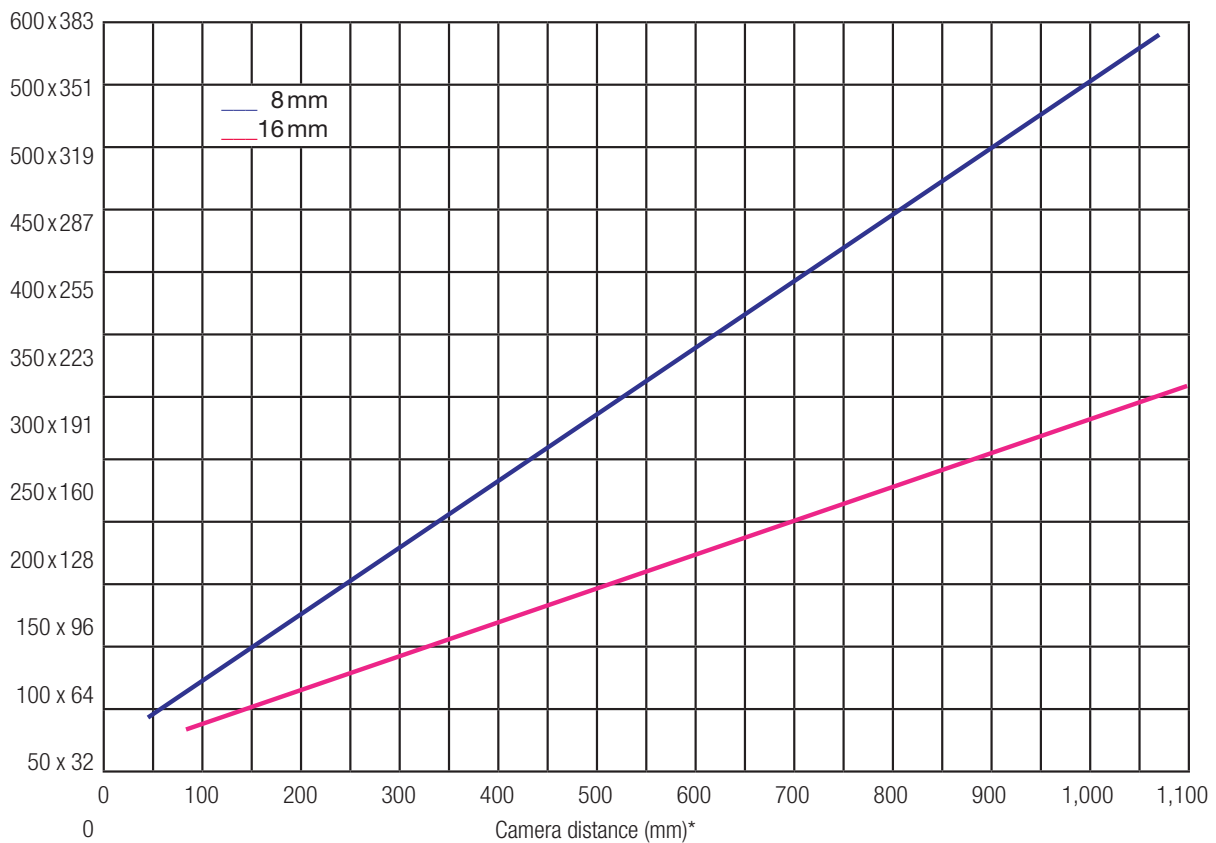

\* For a distance of up to 250 mm, particularly homogeneous illumination of the field of view is ensured by the integrated illumination. Larger camera distances can be realized as well with the system — if necessary with external illumination. For this purpose, the axes of the diagram need only be extrapolated.

# E SERIES

## C-MOUNT LENS

The diagram shows the field of view depending on the camera distance for C-mount lenses with different focal lengths which must be ordered as a separate accessory. The camera distance is the distance between the front edge of the camera and the object.

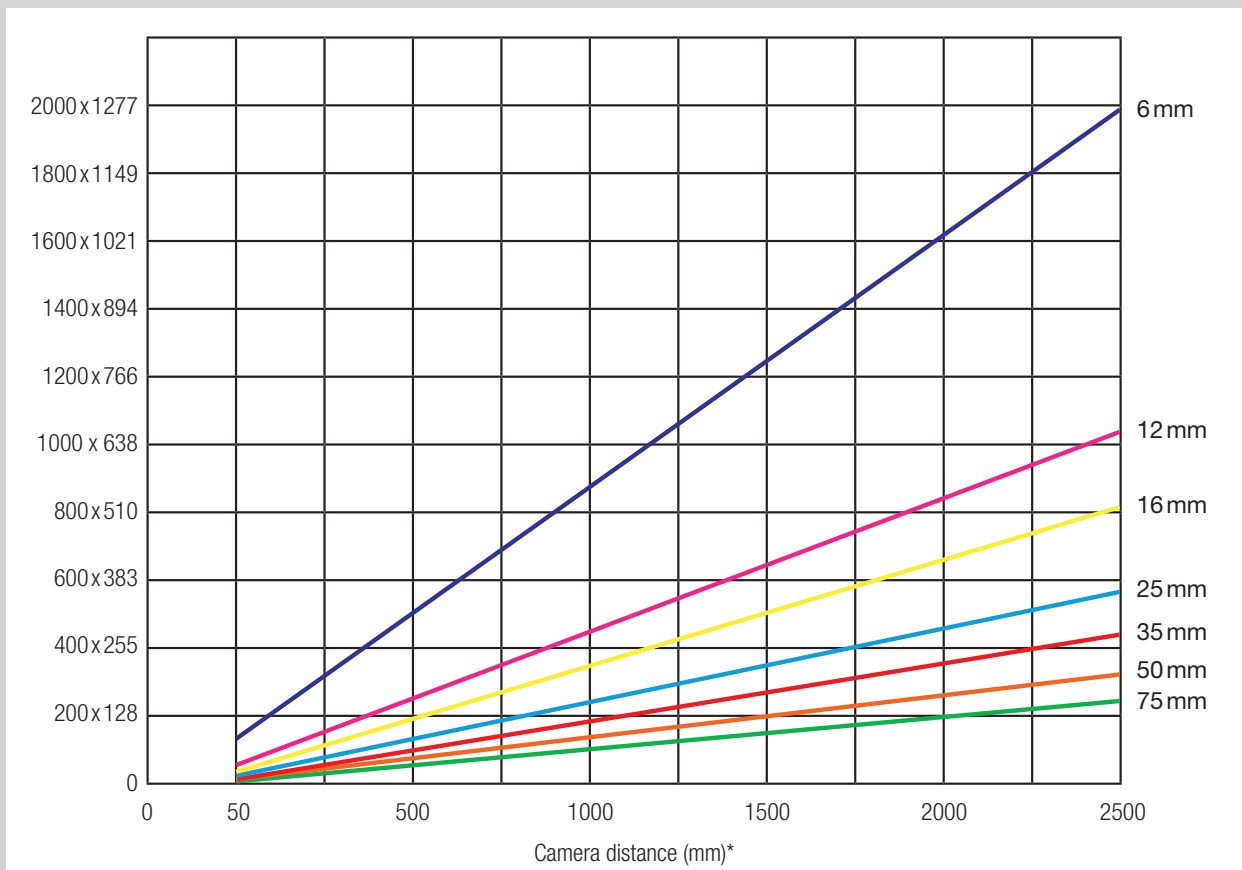

\* Camera distances greater than 2500 mm can be realized. In this case, the axis of the diagram is extrapolated accordingly. The use of spacer rings may be necessary in the case of short camera distances.

## FUNCTIONS OVERVIEW

Tasks	LSIS 412i	LSIS 422i	LSIS 462i
<b>BLOB analysis</b>			
Presence/completeness	X	–	X
Type detection	X	–	X
Position, angle	X	–	X
Repositioning (X, Y, 360 °)	X	–	X
Up to 99 objects per tool	X	–	X
<b>Code reading</b>			
1D-codes	–	X	X
2D-codes	–	X	X
Omnidirectional reading	–	X	X
Multiple code reading (max. 99)	–	X	X
Reference code comparison	–	X	X
Quality parameters for printed 1D- and 2D-codes	–	X	X
Display of the read result	–	X	X
<b>Measurement</b>			
Point, line, distance, circle	–	–	X
Edge count	–	–	X
Coordinate measurement	–	–	X
<b>Additional functions</b>			
Integrated homogeneous LED illumination	X	X	X
Motor-driven focus adjustment*	X	X	X
Software operation with a standard web browser	X	X	X
Statistical information	X	X	X
Image memory	X	X	X
Result documentation	X	X	X
Program change (dig. I/O)	X	X	X
Multi-language display	X	X	X
Online help	X	X	X
Real-time clock	X	X	X
Display of the process time	X	X	X
User management	X	X	X
Storage for max. 100 programs	X	X	X
<b>Options</b>			
Cable	○	○	○
Mounting material	○	○	○
External illumination	○	○	○

## COMMON TECHNICAL DATA

<b>Electrical data</b>	
Operating voltage	18 ... 30 V DC (PELV, Class 2)
Power consumption	Max. 10 W, C-mount model
Process interface	RS 232, Ethernet 10/100 Mbit/s
Service interface	Ethernet 10/100 Mbit/s
Switching inputs/outputs	8, freely configurable
Inputs	18 ... 30 V DC
Outputs	Max. 60 mA output, max. 100 mA total current
<b>Optical data</b>	
Image sensor	Global shutter CMOS
Number of pixels	752 x 480
Electronic shutter speeds	54 µs ... 20 ms
Integrated LED illumination*	White, infrared or RGBW
Focal length	8mm / 16mm / C-mount
Object distance	50 mm ... ∞ / 75 mm ... ∞ / on request
<b>Mechanical data</b>	
Degree of protection	IP 65 / 67
VDE protection class	III
Housing	Die-cast aluminum
Weight	500 g
Dimensions (L x W x H)	113 x 75 x 55 mm <sup>3</sup> (standard device) 113 x 75 x 109 mm <sup>3</sup> (C-mount model)
<b>Environmental data</b>	
Ambient temperature operation (storage)	0 °C ... +45 °C (–20 °C ... +70 °C)
Rel. air humidity (non-condensing)	Max. 90 %
Laser class	LED Class 1 acc. to EN 60825-1:2003-10
Vibration	IEC 60068-2-6, test Fc
Shock	IEC 60068-2-27, test Ea
Continuous shock	IEC 60068-2-29, test Eb
Electromagnetic compatibility	EN 61000-6-2, EN 61000-6-4 IEC 60068-2-27, test Ea

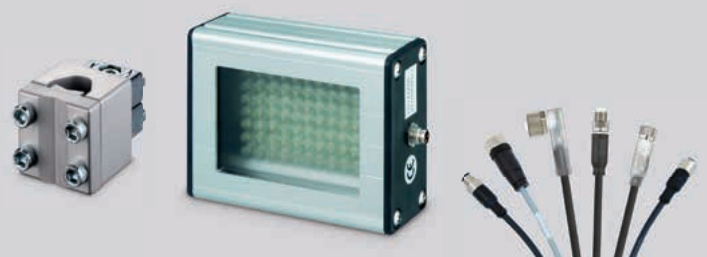



# OUR PROMISE TO YOU

## SMARTER **PRODUCT USABILITY**

With regard to our product developments, we systematically place emphasis on the especially good usability of all devices. To this end, simple mounting and alignment are taken into account – just as the uncomplicated integrability of the sensors in existing field bus systems and easy configuration, e.g. via a web browser, are.

## SMARTER **APPLICATION KNOW-HOW**

Whoever can do it all, can do nothing right. Which is why we concentrate on selected target sectors and applications. There, we are specialists and know all aspects inside out. For this purpose, we optimize our solutions and offer a comprehensive product range that makes it possible for our customers to obtain the absolute best solutions from a single source.

## SMARTER **CUSTOMER SERVICE**

The technical and personal proximity to our customers, and a skilled, straightforward handling of queries and problems, are among our strengths – and will remain so. Consequently, we will continue to expand our service offerings and, indeed, also forge ahead in new directions to persistently redefine the utmost in customer service. Whether on the phone, on the Internet or on-site with our customers – regardless of when and where the expertise of the sensor people is needed at any time.

Info at: [www.leuze.com](http://www.leuze.com)



Martina Weil,  
Employee in the  
Customer Care Center



### **Switching Sensors**

Optical Sensors  
Ultrasonic Sensors  
Fiber Optic Sensors  
Inductive Switches  
Forked Sensors  
Light Curtains  
Special Sensors

### **Measuring Sensors**

Distance Sensors  
Sensors for Positioning  
3D Sensors  
Light Curtains  
Forked Sensors

### **Products for Safety at Work**

Optoelectronic Safety Sensors  
Safe Locking Devices, Switches and Proximity Sensors  
Safe Control Components  
Machine Safety Services

### **Identification**

Bar Code Identification  
2D-Code Identification  
RF Identification

### **Data Transmission / Control Components**

MA Modular Connection Units  
Data Transmission  
Safe Control Components  
Signaling Devices  
Connection Technology and Passive Distribution Boxes

### **Industrial Image Processing**

Light Section Sensors  
Smart Camera

Leuze electronic GmbH + Co. KG  
In der Braike 1  
73277 Owen  
Phone +49 7021 573-0  
Fax +49 7021 573-199  
info@leuze.de  
www.leuze.com